

SKIRTING-FRINGE (SF): EXTRUDED BRUSH PILE SEALS

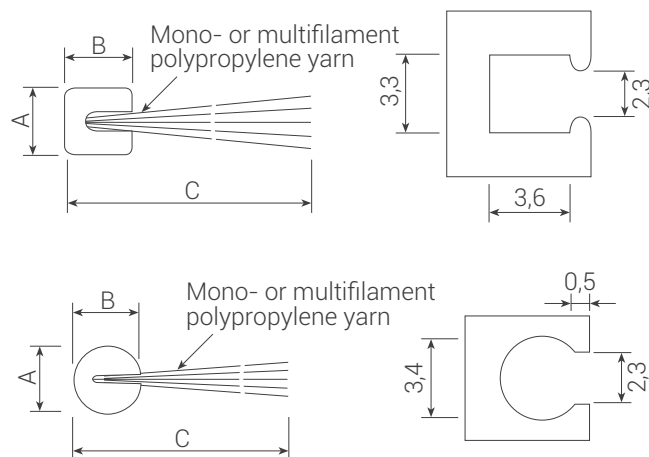

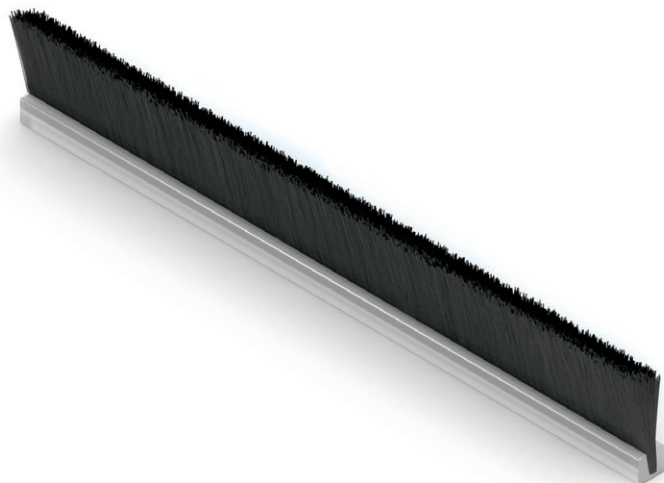



Extruded square or round base for sealing of gaps at the edges of swing doors, roller shutters and other similar narrow profile applications. Stiffer untreated 6-ply monofilament or softer silicone treated multifilament yarn. Other base shapes and dimensions are available upon request.

Recommended compression:

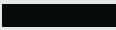
- 15-20 %

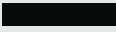
TECHNICAL SPECIFICATION

| STANDARD SOLUTIONS | | | |
|----------------------|---|---|--|
| A Base width | B Base height | C Brush height | Monofilament density in 1 line |
| Square 2,7 ± 0,15 mm | 2,7 (+0,15 / -0,35) 2,9 (+0,15 / -0,35) 3,1 (+0,15 / -0,35) 3,3 (+0,15 / -0,35) | 5,0 ≤ H ≤ 30,0 ± 0,5 mm with 1,0 mm intervals | 24 |
| Square 2,9 ± 0,15 mm | | | Monofilament pile yarn colours (≈ RAL) |
| Square 3,1 ± 0,15 mm | | | 9005   |
| Square 3,3 ± 0,15 mm | | | Black Natural |
| Round 2,7 ± 0,15 mm | | | Multifilament density (P) in 1 line |
| Round 2,9 ± 0,15 mm | | | 4P |
| Round 3,1 ± 0,15 mm | | | Multifilament pile yarn colours (≈ RAL) |
| Round 3,3 ± 0,15 mm | 9005  7045  | | |
| | | | Black Grey |